

1 2 3 4 5 6 7 8 9 10 11 12 13 14 15 16 17 18

A
B
C
D
E
F
G
H

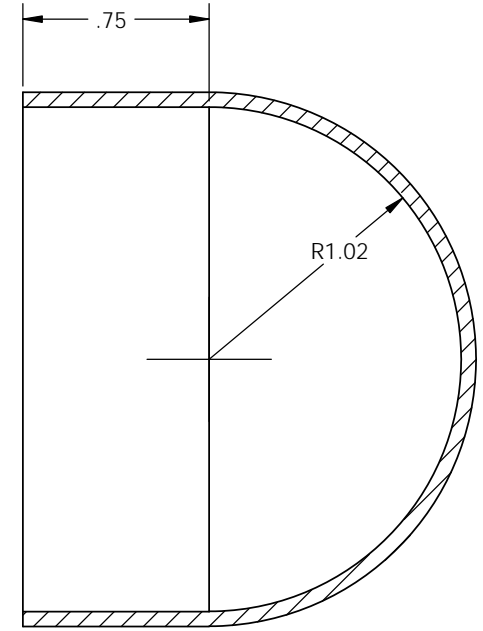
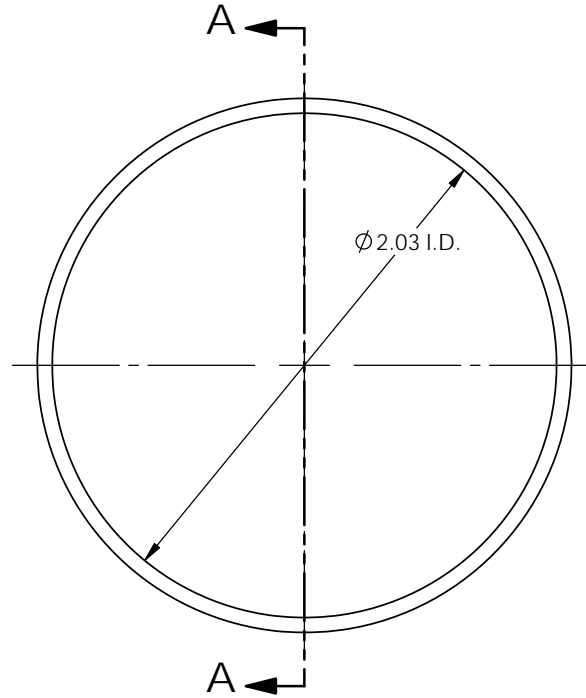
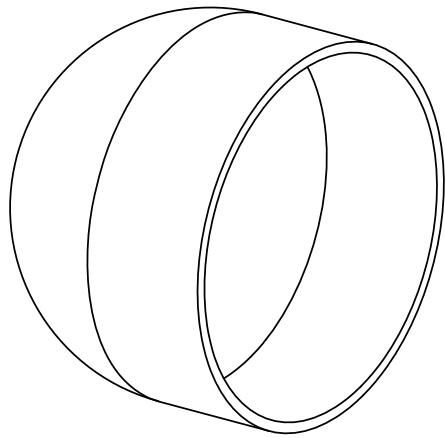

SECTION A-A
SCALE 2 : 1

Notes:

1. Finished material thickness can range from 0.030" to 0.125" depending upon customer requirement.
2. Parts formed on Toledo Metal Spinning Company tooling.
3. Optional outside brush finish available per request.



TOLEDO METAL SPINNING COMPANY

1819 Clinton Street, Toledo, OH 43607
 Tel:(419) 535-5931, Fax: (419) 535-0565
 www.toledometalsspining.com

P/N: HM0203-0075
Material: Aluminum, Mild Steel, Stainless Steel
Parent Metal Thickness: 0.060" ~ 0.187"
DWG #: HM0203-0075

Date: 09.18.2009
Drawn By: L.F.
Scale: 2:1

Unless otherwise specified:

1. Tolerances:
 X. ±0.25 X.XXX ±0.005
 X.X ±0.12 X.XXXX ±0.001
 X.XX ±0.03 Ang. ±1°
2. All dimensions are in inches
3. Break all edges with R1/32" to R1/16"