

1 2 3 4 5 6 7 8 9 10 11 12 13 14 15 16 17 18

A  
B  
C  
D  
E  
F  
G  
H  
I

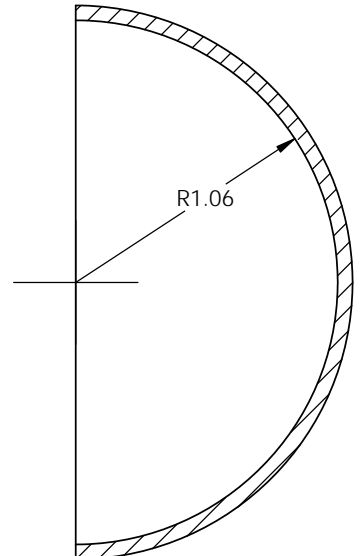
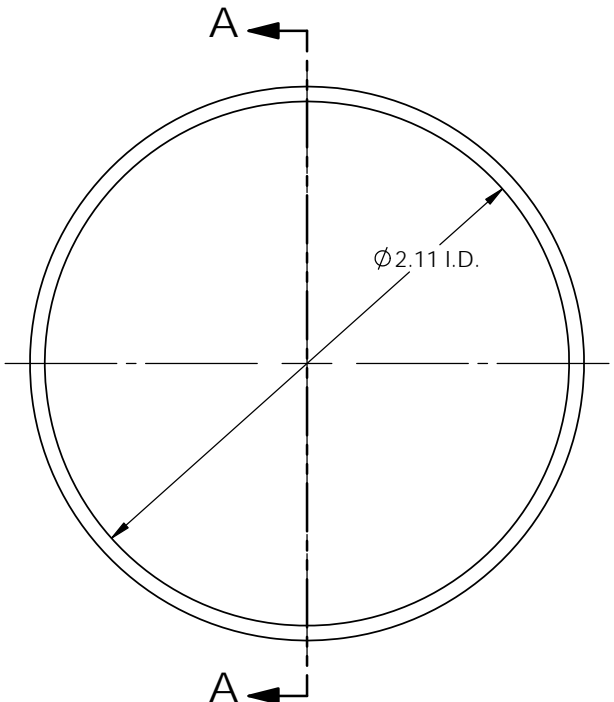
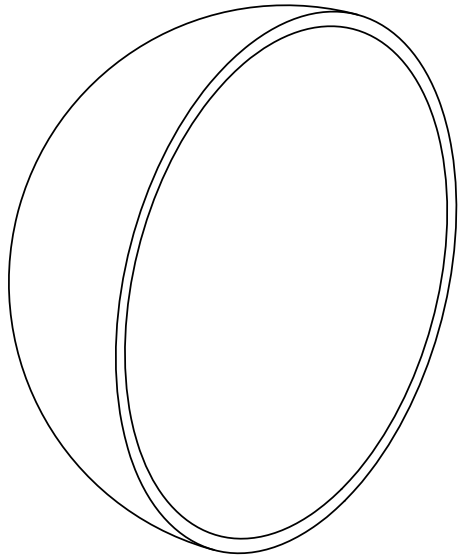

SECTION A-A  
SCALE 2 : 1

- Notes:
1. Finished material thickness can range from 0.030" to 0.125" depending upon customer requirement.
  2. Parts formed on Toledo Metal Spinning Company tooling.
  3. Optional outside brush finish available per request.



**TOLEDO METAL SPINNING COMPANY**

1819 Clinton Street, Toledo, OH 43607  
 Tel:(419) 535-5931, Fax: (419) 535-0565  
 www.toledometalsspining.com

P/N: HM0211-0000
Material: Aluminum, Mild Steel, Stainless Steel
Parent Metal Thickness: 0.060" ~ 0.187"
DWG #: HM0211-0000

Date: 09.18.2009
Drawn By: L.F.
Scale: 2:1

Unless otherwise specified:	
1. Tolerances:	
X. ±0.25	X.XXX ±0.005
X.X ±0.12	X.XXXX ±0.001
X.XX ±0.03	Ang. ±1°
2. All dimensions are in inches	
3. Break all edges with R1/32" to R1/16"	