



**TOLEDO METAL SPINNING CO.**  
 1819 Clinton Street, Toledo, OH 43607  
 Tel:(419)535-5931 Fax:(419)535-0565  
 www.toledometalsspining.com

P/N: TMS16314  
 Desc: TMS SS Hopper  
 Material: 14 Ga. SS304  
 DWG# TMS16314.dwg  
 Rev# 0-1

Unless otherwise specified (DU = Inches)  
 Tolerances:  
 X. ±0.25 XX ±0.030 XXXX ±0.001  
 XX ±0.12 XXX ±0.010 Ang. ±0.25  
 Break all edges with R1/32" to R1/16"

REV. 0-1  
 CHG. FROM 16.08  
 TO 16.00 ID  
 9/23/05

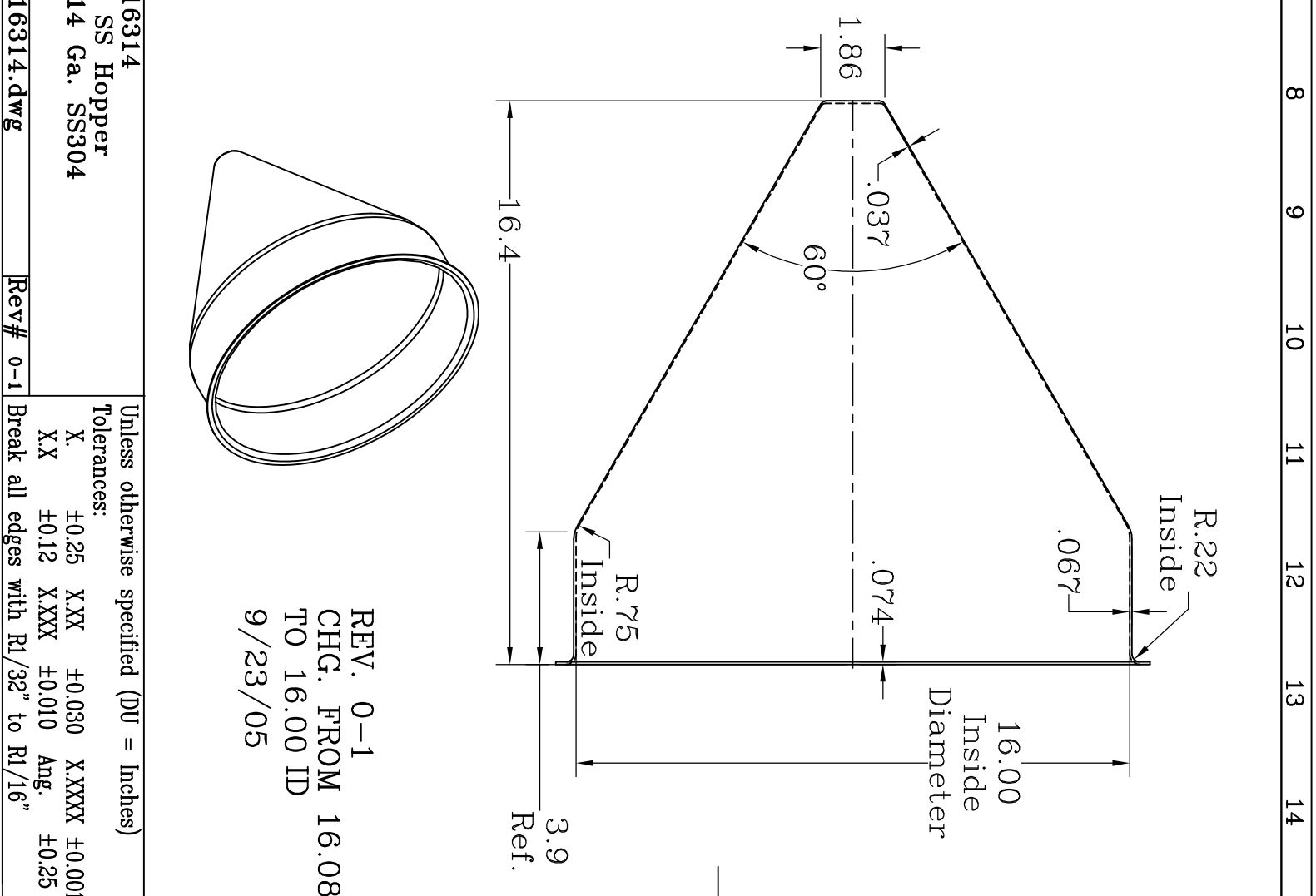
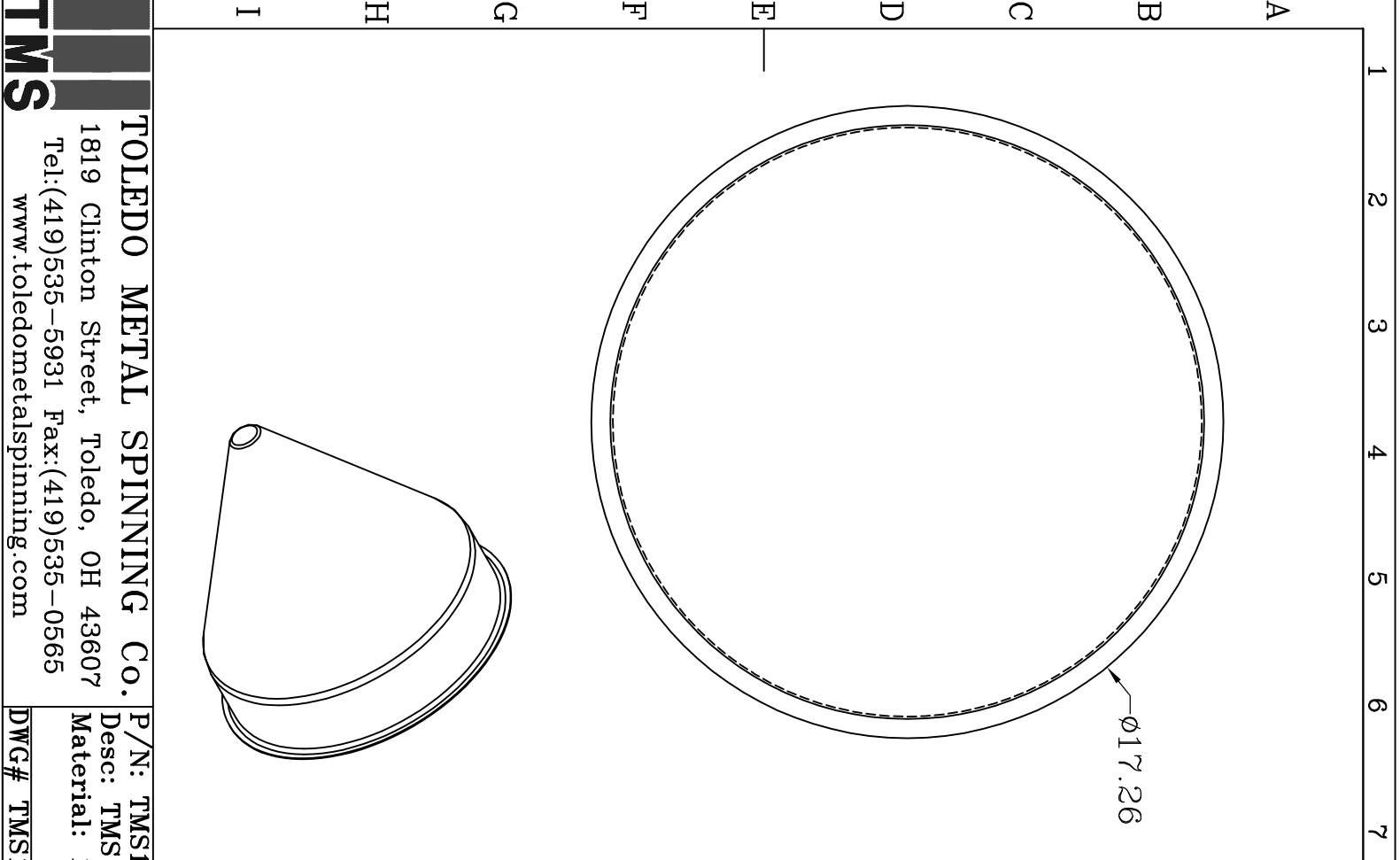

16.00  
 Inside  
 Diameter  
 3.9  
 Ref.