

REVISIONS				
ZONE	REV.	DESCRIPTION	DATE	APPROVED
	A	INITIAL RELEASE FOR MANUFACTURING	30MAY2014	B. KEEL

NOTES UNLESS OTHERWISE SPECIFIED

1. MATERIAL: 304 STAINLESS STEEL
2. FINISH: NO METAL FINISHING REQUIRED. THE FINAL FINISH SHALL BE THE RESULT OF THE PROCESSES USED TO FABRICATE THE SHAPE.
3. REMOVE ALL SHARP EDGES AND BURRS. BREAK WITH A .02 IN X 45 DEG CHAMFER OR .02 IN RADII.

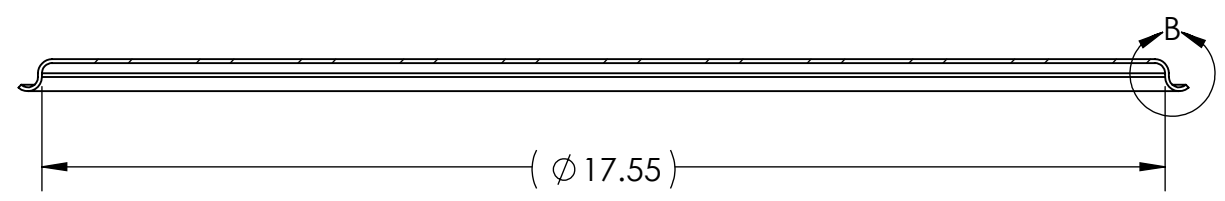
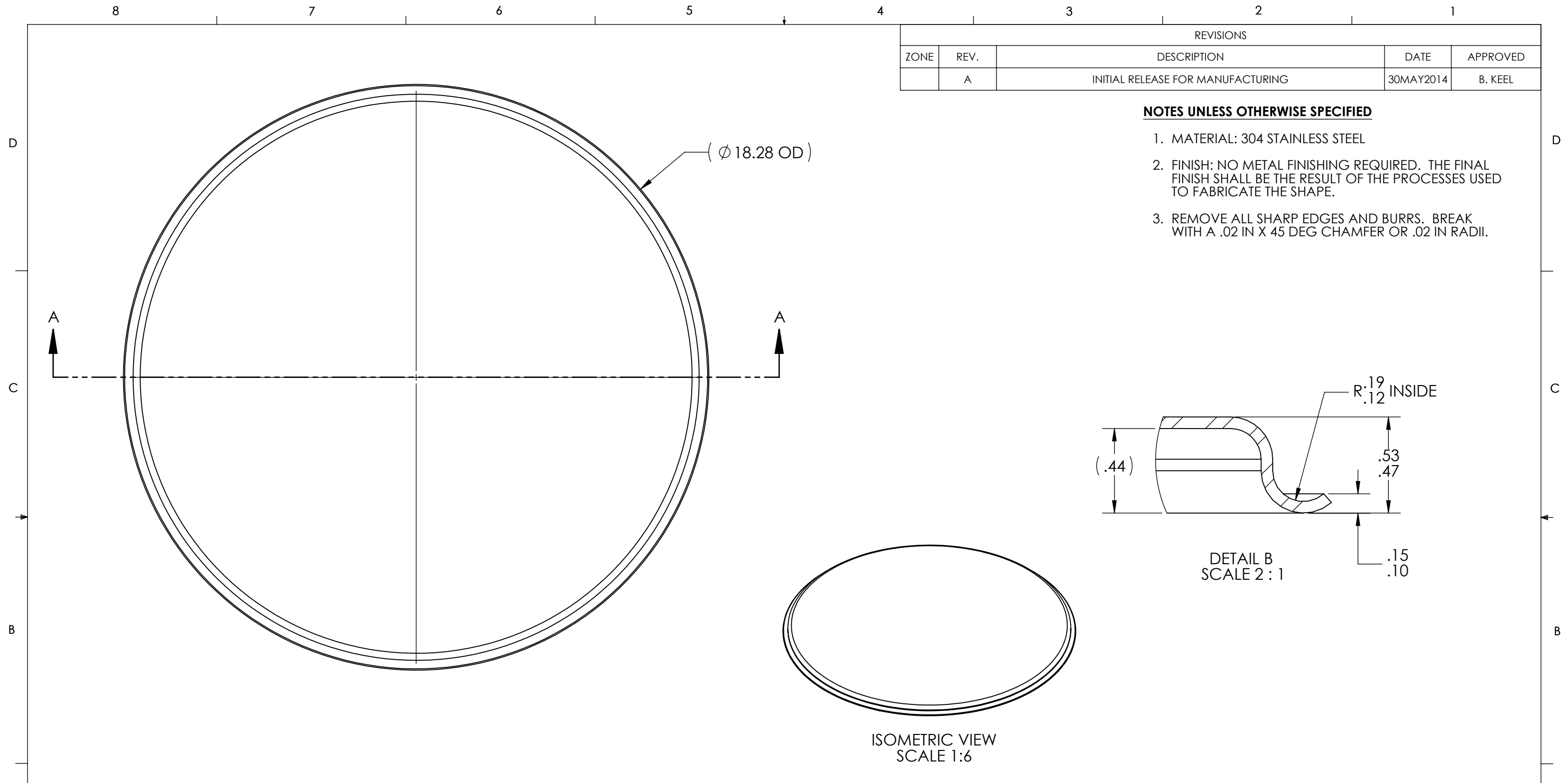

SECTION A-A

ISOMETRIC VIEW
SCALE 1:6

DETAIL B
SCALE 2:1

UNLESS OTHERWISE SPECIFIED:		NAME	DATE	TOLEDO METAL SPINNING Co.	
1. DIMENSIONS ARE IN INCHES		DRAWN	B. KEEL	30MAY2014	
2. TOLERANCE:		CHECKED		TITLE:	
FRACTIONAL ± .25		ENG APPR.		TMSL1616-BEADED	
X.X ± .1		MFG APPR.		SIZE	
X.XX ± .03		Q.A.		DWG. NO.	
X.XXX ± .01		COMMENTS:		REV	
ANGULAR: ± 2 DEG.				A	
3. THIRD ANGLE PROJECTION				SCALE: 1:3	
INTERPRET DRAWING PER ASME-Y14.5M-1994 STANDARDS				WEIGHT:	
MATERIAL				SHEET 1 OF 1	
FINISH					
DO NOT SCALE DRAWING					

PROPRIETARY AND CONFIDENTIAL
THE INFORMATION CONTAINED IN THIS DRAWING IS THE SOLE PROPERTY OF TOLEDO METAL SPINNING COMPANY. ANY REPRODUCTION IN PART OR AS A WHOLE WITHOUT THE WRITTEN PERMISSION OF TOLEDO METAL SPINNING COMPANY IS PROHIBITED.

8 7 6 5 4 3 2 1

8 7 6 5 4 3 2 1

D
C
B
A

D
C
B
A